



**IES ROAD REPORT
PHOTOMETRIC FILENAME : LLI070807D.IES**

DESCRIPTIVE INFORMATION (From Photometric File)

IESNA:LM-63-2002
[TEST] LLI 0708-09D
[TESTLAB] LIGHT LABORATORY INC
[ISSUE DATE] 8/28/2008
[MANUFAC] SINGBEELIGHTING
[LUMCAT] SP-7006
[LUMINAIRE] 19"DIA. X 23-3/8"H. LED LUMINAIRE
[MORE] 1260 COOL WHITE LEDS ON WHITE REFLECTOR
[MORE] FLAT TEMPERED CLEAR LENS
[LAMPCAT] COOL WHITE LED
[OTHER] INDICATING THE CANDELA VALUES ARE ABSOLUTE AND
[MORE] SHOULD NOT BE FACTORED FOR DIFFERENT LAMP RATINGS.
[_INPUT] 120VAC, 108.45W

CHARACTERISTICS

IES Classification	Type V
Longitudinal Classification	Very Short
Cutoff Classification (deprecated)	N.A.
Total Rated Lamp Lumens	N.A. (absolute photometry)
Maximum Candela	2643
Maximum Candela Angle	0H 0V
Maximum Candela At 90 Degrees Vertical	0
Maximum Candela from 80 to <90 Degrees Vertical	99
Downward Total Efficiency	N.A.
Total Luminaire Watts	108
Ballast Factor	1.00

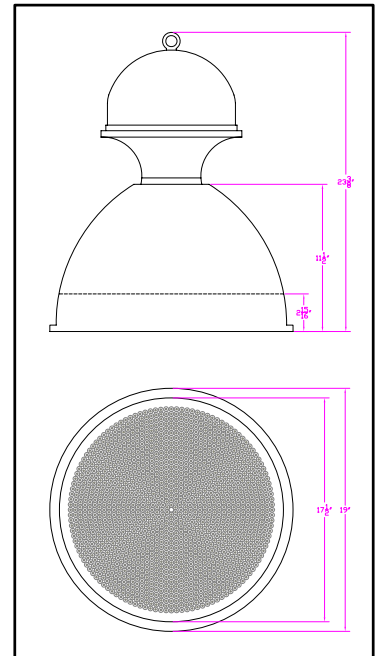

IES ROAD REPORT
PHOTOMETRIC FILENAME : LLI070807D.IES

CANDELA TABULATION

Vert. Angles	Horizontal Angles
	<u>0</u>
0.0	2643
1.0	2643
3.0	2643
5.0	2635
7.0	2623
9.0	2607
11.0	2584
13.0	2558
15.0	2530
17.0	2496
19.5	2439
22.5	2361
25.5	2280
29.0	2170
33.0	2049
37.5	1891
42.5	1694
47.5	1487
55.0	1163
65.0	687
75.0	184
85.0	14
90.0	0

IES ROAD REPORT
PHOTOMETRIC FILENAME : LLI070807D.IES

FLUX DISTRIBUTION

	Lumens	Percent Of Lamp
Downward Street Side	3236.6	N.A.
Downward House Side	3236.6	N.A.
Downward Total	6473.2	N.A.
Upward Street Side	0.0	N.A.
Upward House Side	0.0	N.A.
Upward Total	0.0	N.A.
Total Flux	6473.2	N.A.

POLAR GRAPH

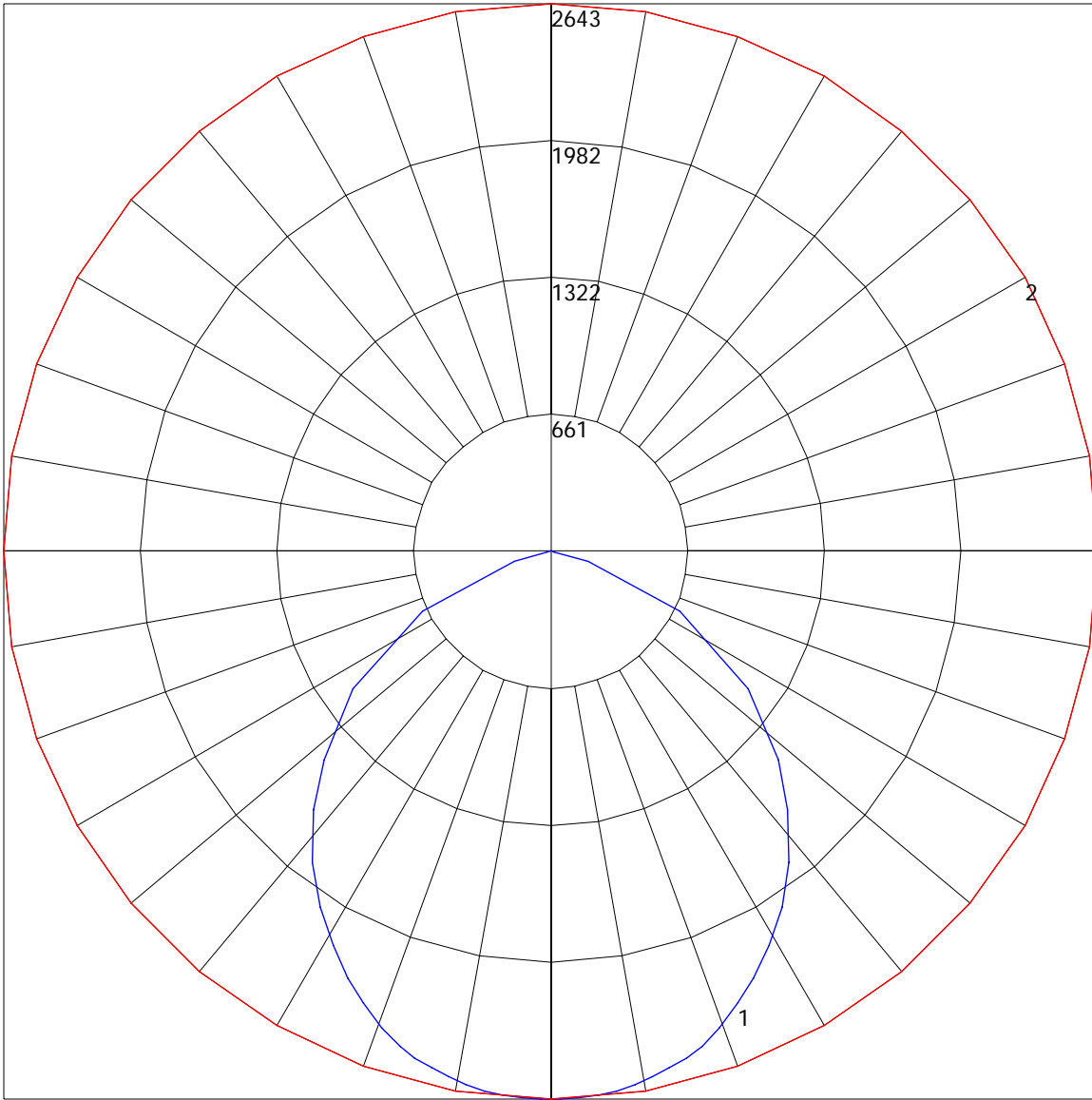

Maximum Candela = 2643 Located At Horizontal Angle = 0, Vertical Angle = 0
1 - Vertical Plane Through Horizontal Angles (0 - 180) (Through Max. Cd.)
2 - Horizontal Cone Through Vertical Angle (0) (Through Max. Cd.)

ISOFOOTCANDLE LINES OF HORIZONTAL ILLUMINANCE

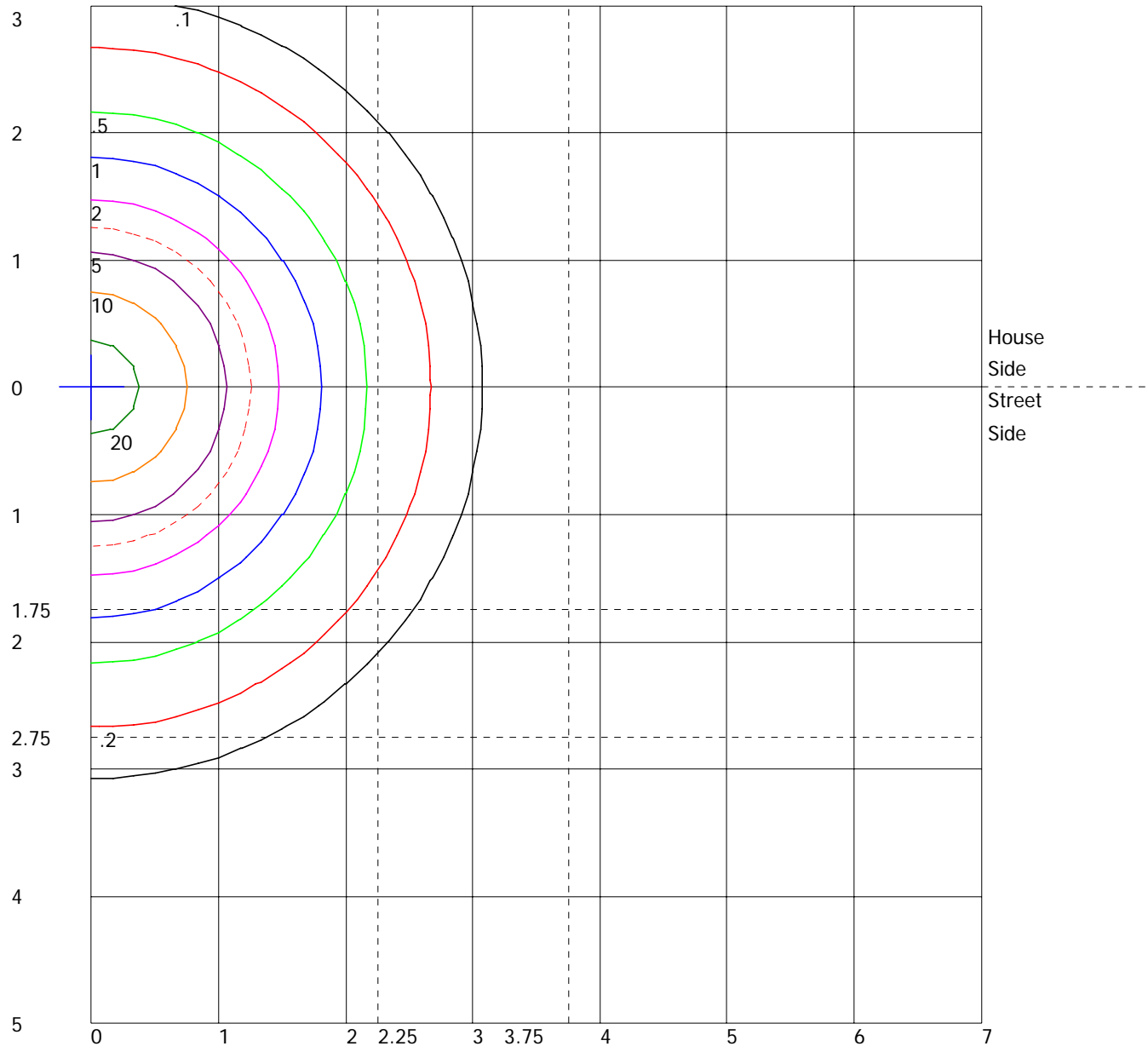

Distance In Units Of Mounting Height
 Values Based On 10 Foot Mounting Height
 1/2 Maximum Candela Trace Shown As Dashed Curve
 (+) = Maximum Candela Point